



FRAMELESS SLIDING GLASS WALL

SGL-1116

INSTALLATION GUIDE

132 32nd Street,
Suite 120 Brooklyn, NY 11232

 (718) 690 02 58

 sales@crystaliaglass.com

 [@crystaliaglass](https://www.instagram.com/crystaliaglass)



 crystaliaglass.com

SUMMARY OF TOOLS AND PARTS





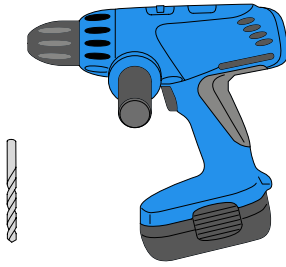
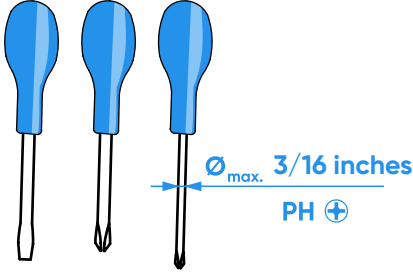
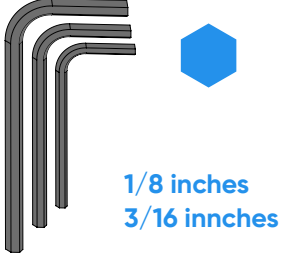
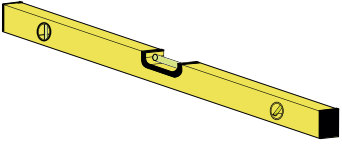
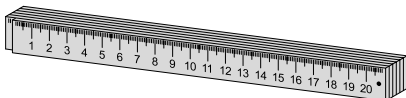
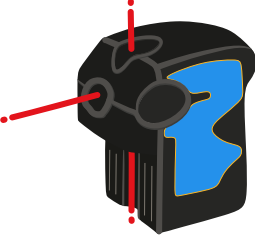
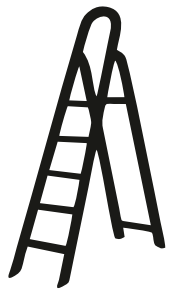

It is important to follow all steps in this guide in order to ensure the correct installation of the CRYSTALIA GLASS SLIDE system.

0.1 TOOLS

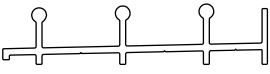
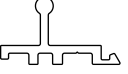
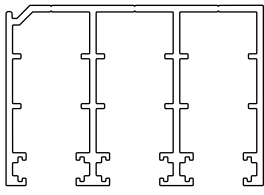
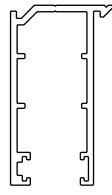
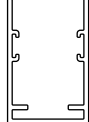
| | | |
|---|--|---|
|  |  |  |
|  |  |  |
|  |  | |

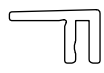
0.2 PARTS

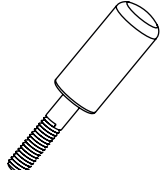
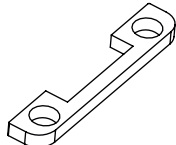
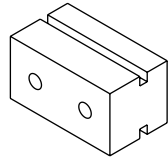
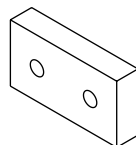
| | | | |
|---|---|--|---|
|  <p>CRDA201</p> |  <p>CRDA202</p> |  <p>CRDA203</p> |  <p>CRDA204</p> |
|  <p>CRDA006</p> |  <p>CRDAI201</p> |  <p>CRDAI206</p> |  <p>CRDAI207</p> |
|  <p>CRD080</p> |  <p>CRD083</p> |  <p>CRD216</p> |  <p>CRD217</p> |

3/8 INCHES GLASS

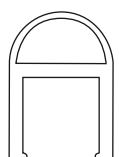
| |
|---|
|  <p>SIS0532</p> |
|  <p>SIS018</p>  <p>SIS019</p> |

1/2 INCHES GLASS

| |
|---|
|  <p>SIS050</p> |
|  <p>SIS100</p> |

CRYSTALIA GLASS DOES NOT RECOMMEND COATING THE BOTTOM TRACK.
If coated, the warranty will not cover any paint damage as a result of use.

1. TRACK FITTING^{*(1)}



THE BOTTOM TRACK MUST BE PLACED ON A FIRM, LEVELED BASE.

1.1 TRACK LEVELING

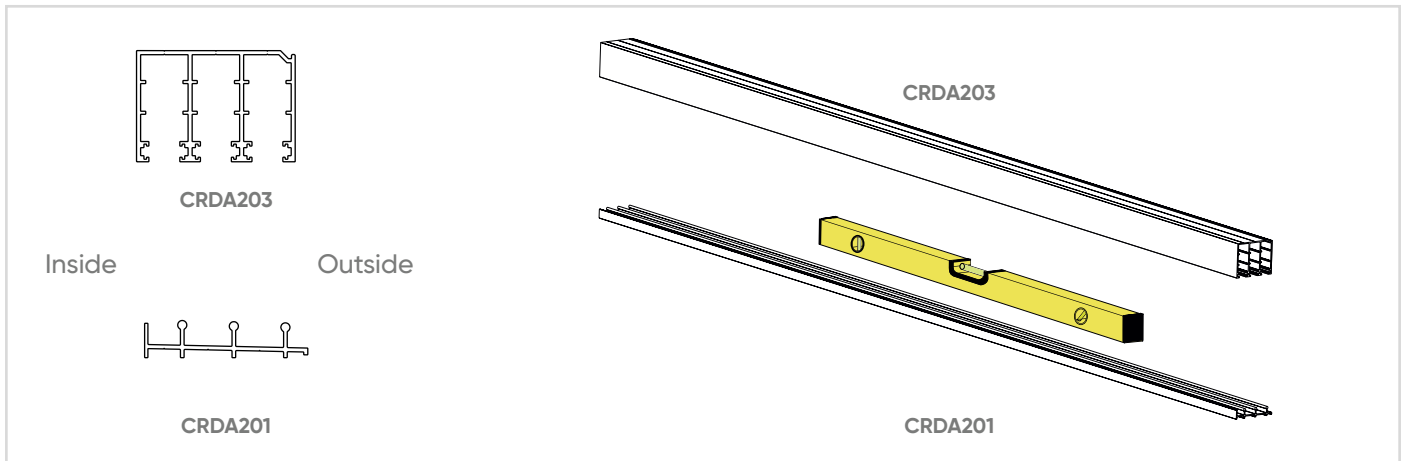

1.1* TRACK LEVELING WHEN ADDITIONAL GUIDE RAILS ARE USED*

*Extra guide rail (CRDA202).

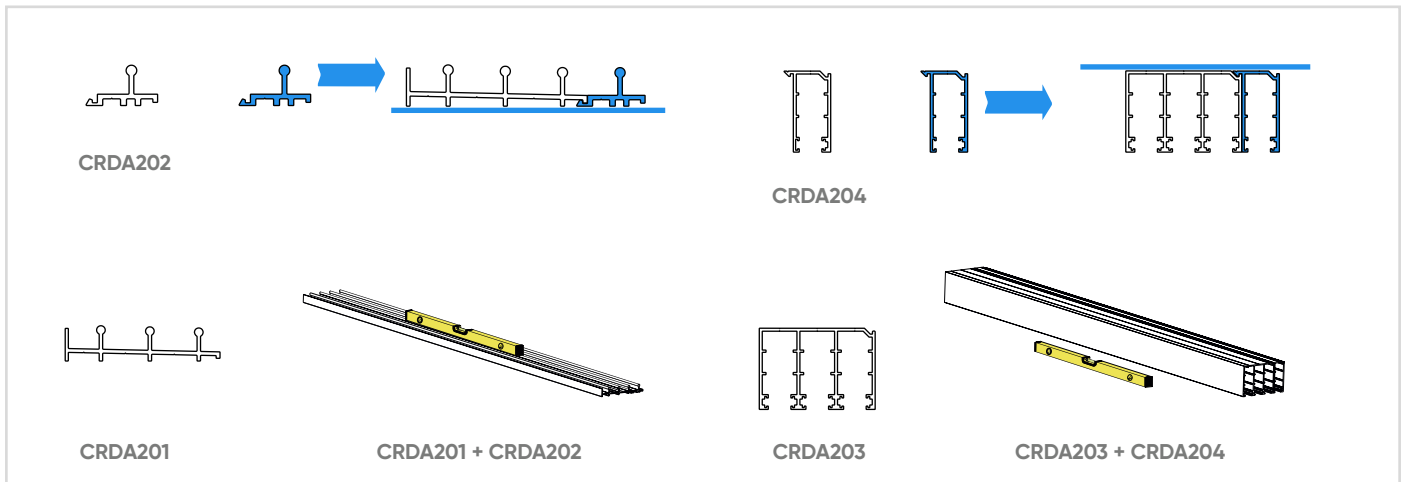

1.2 TRACK LEVELING WHEN ADDITIONAL GUIDE RAILS ARE USED

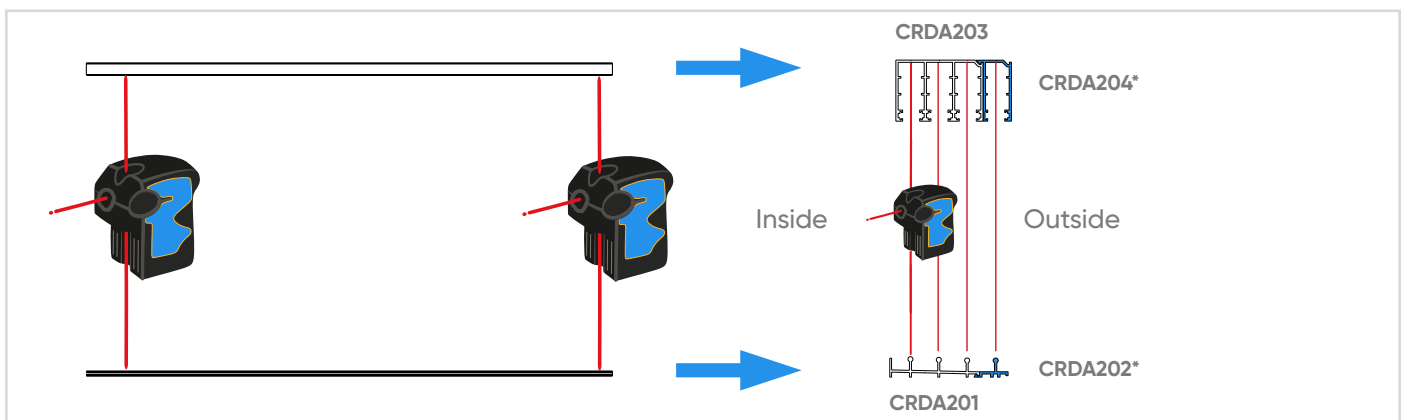



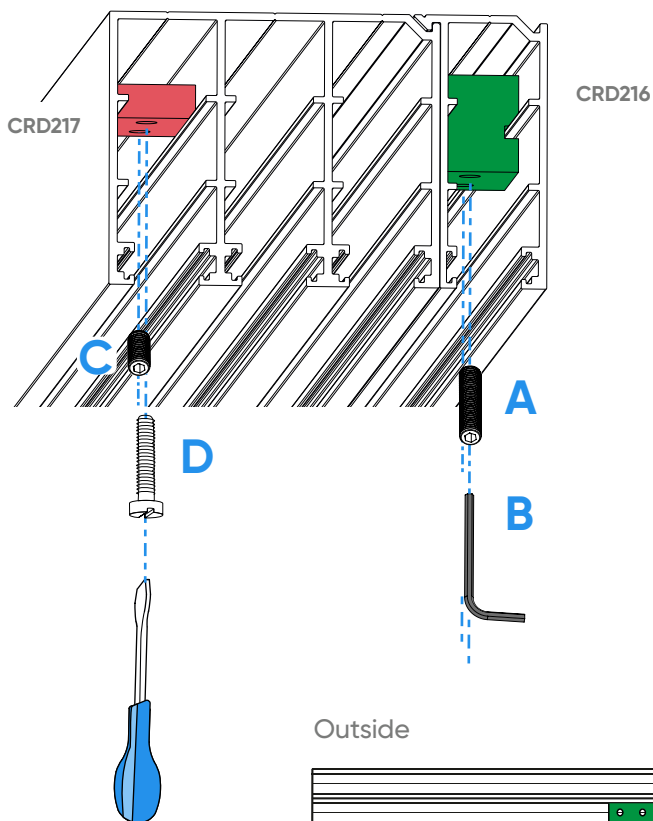
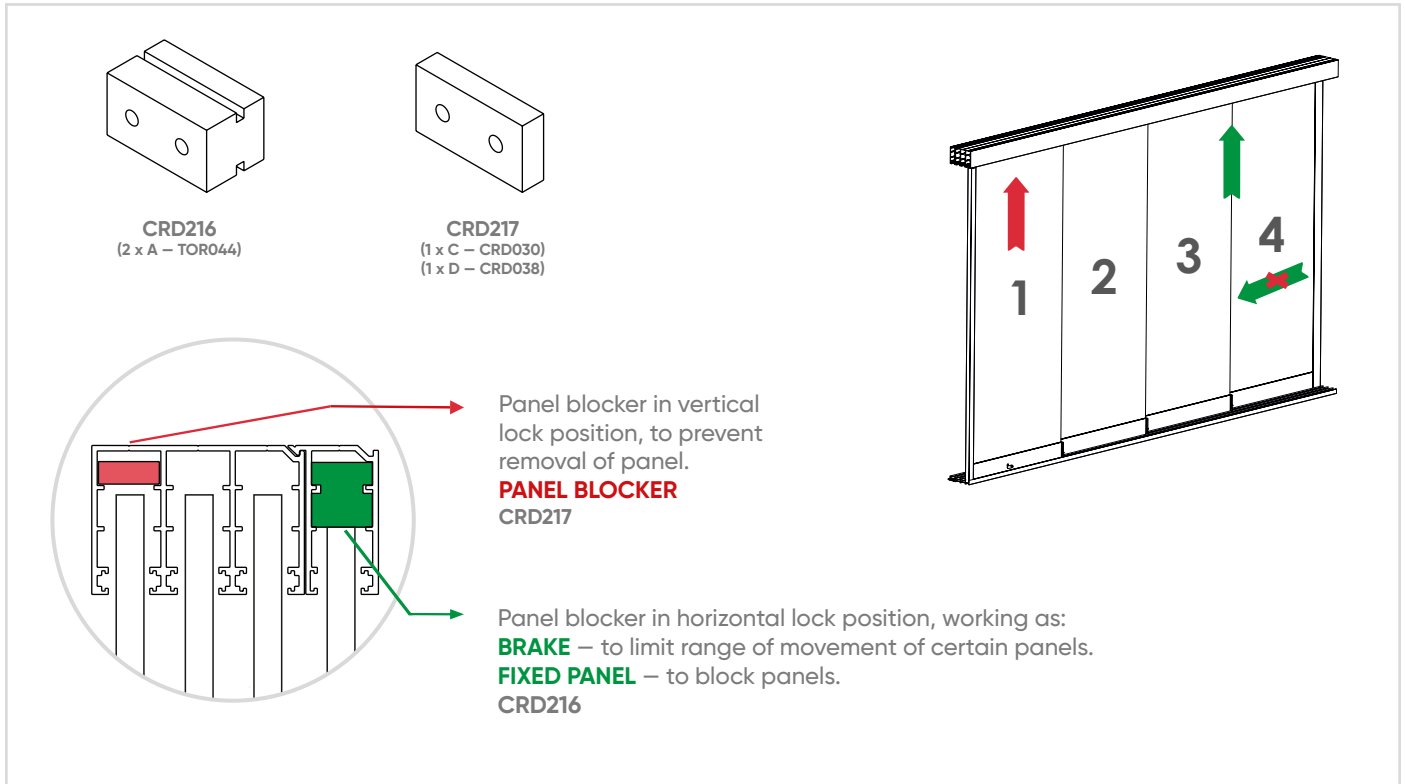

^{*(1)}. ANNEX 1. TRACK FITTING - SLIDE MINI

*Extra guide rail

2. PANEL BLOCKER INSTALLATION IN THE TOP TRACK



| | |
|------------------------------|---|
| A |  |
| DIN 914 A2 M6 x 40 TOR044 | |
| B |  |
| 3 mm | |
| C |  |
| DIN 914 M6 x 20 CRD030 | |
| D |  |
| DIN 84 M6 x 30 TOR038 | |

3. TRACK FITTING



The dimensions of the fixing screws will depend on the installation conditions.

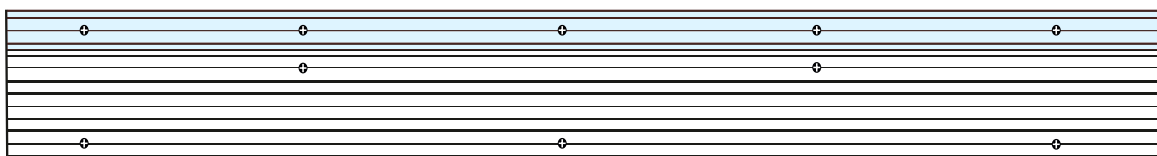
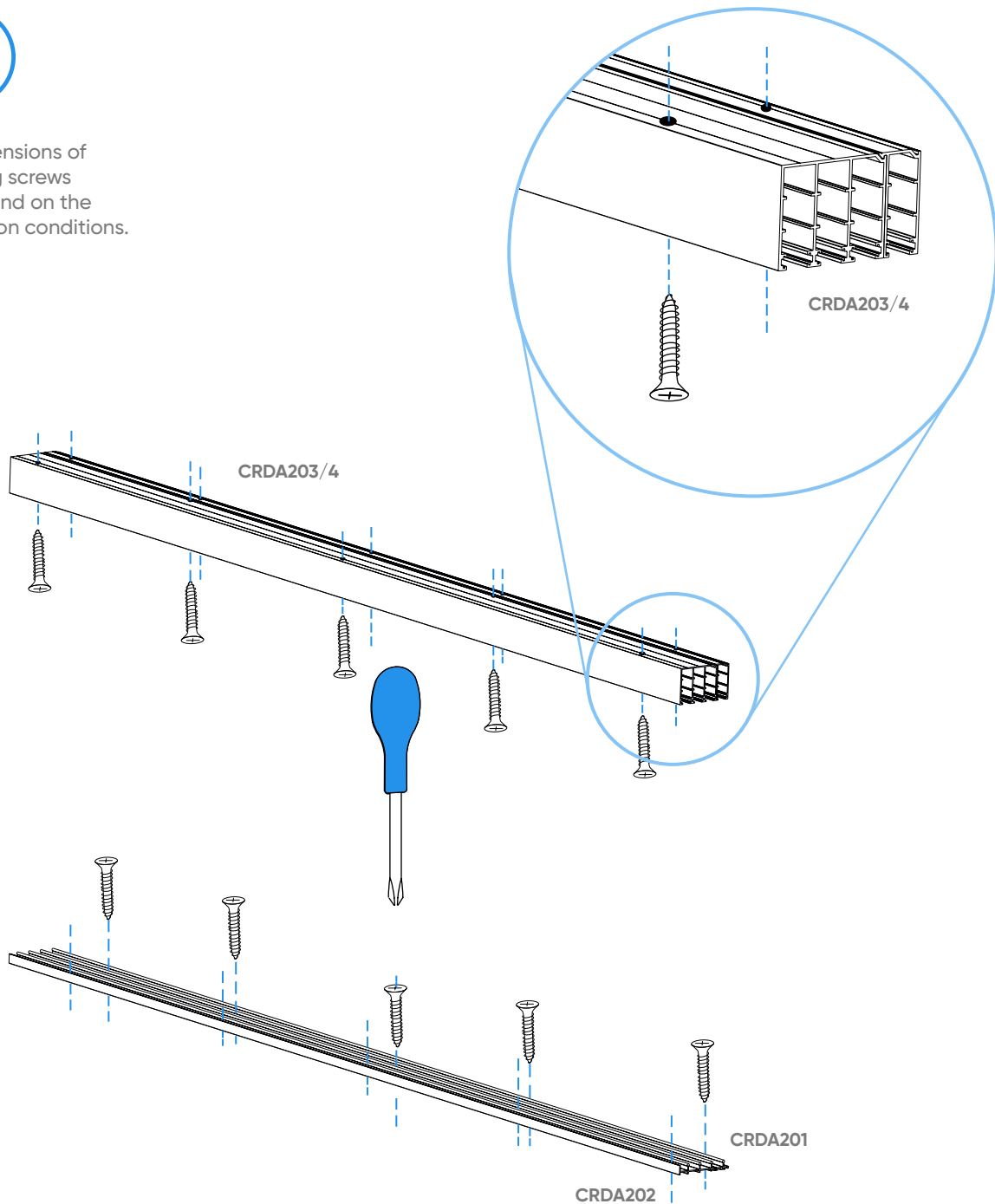

Extra guide rail
CRDA204

Top track
CRDA204

4. PANEL PLACEMENT IN TRACKS

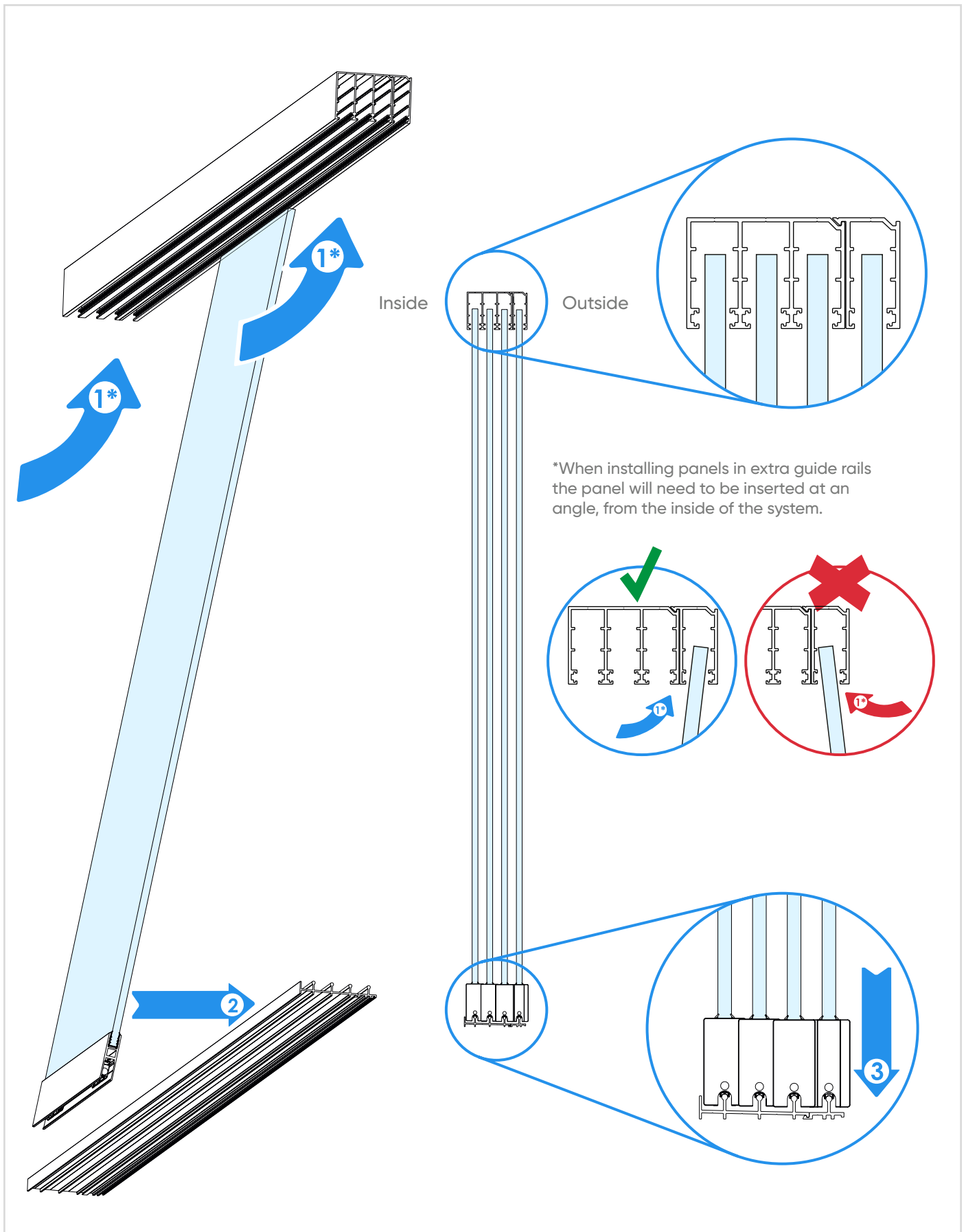

5. "U" SHAPED END PROFILE INSTALLATION

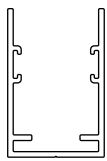

CRDA006

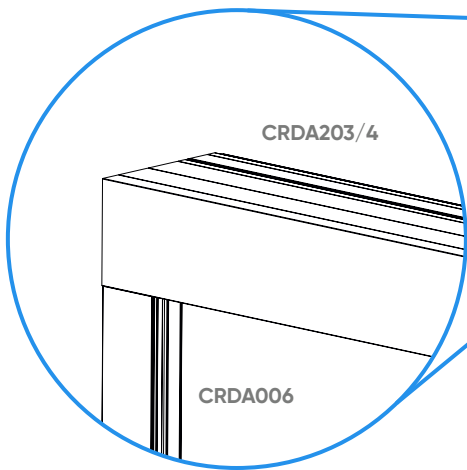

CRDA203/4

CRDA006

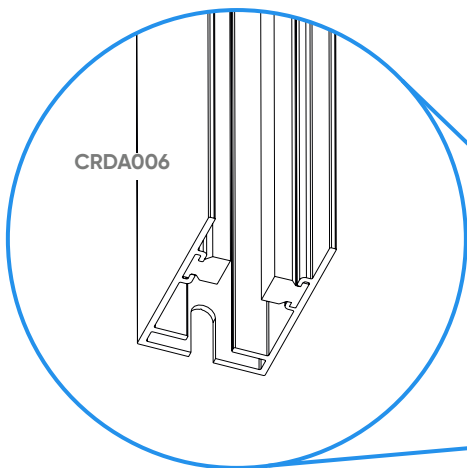

CRDA006

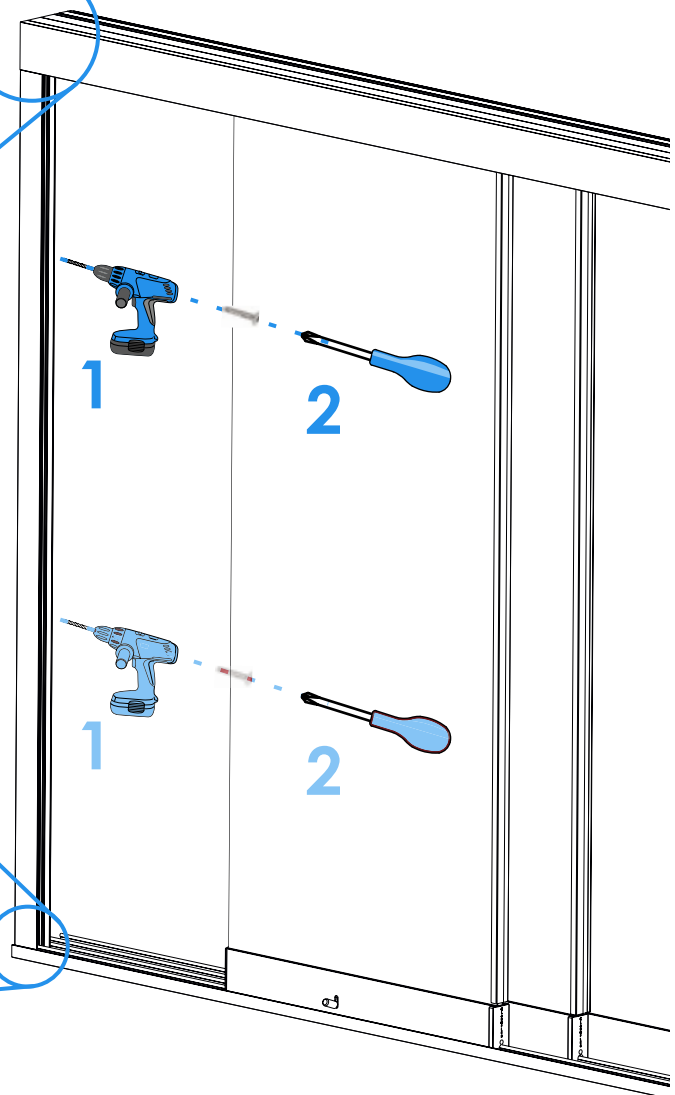

The dimensions of the fixing screws will depend on the installation conditions.



For more information on installing the "U" shaped end profile, consult technical instruction manual It03 CRD2020

6. PANEL ADJUSTMENT

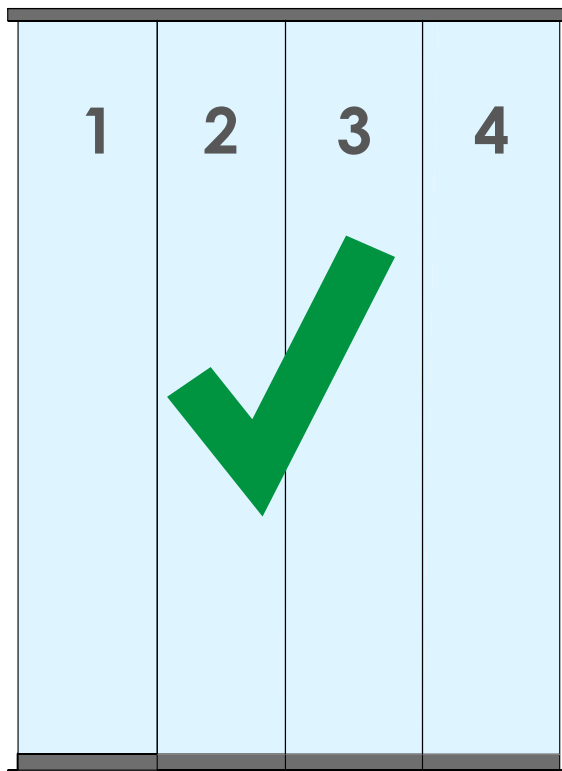
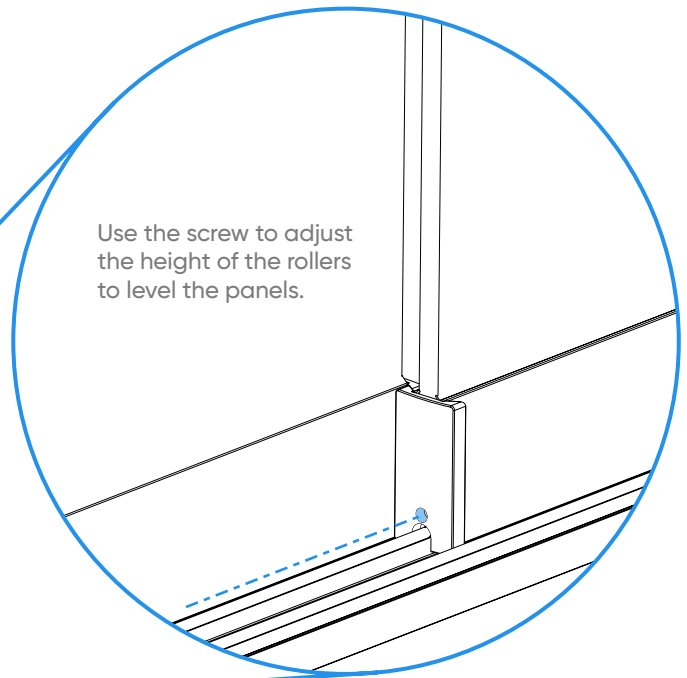
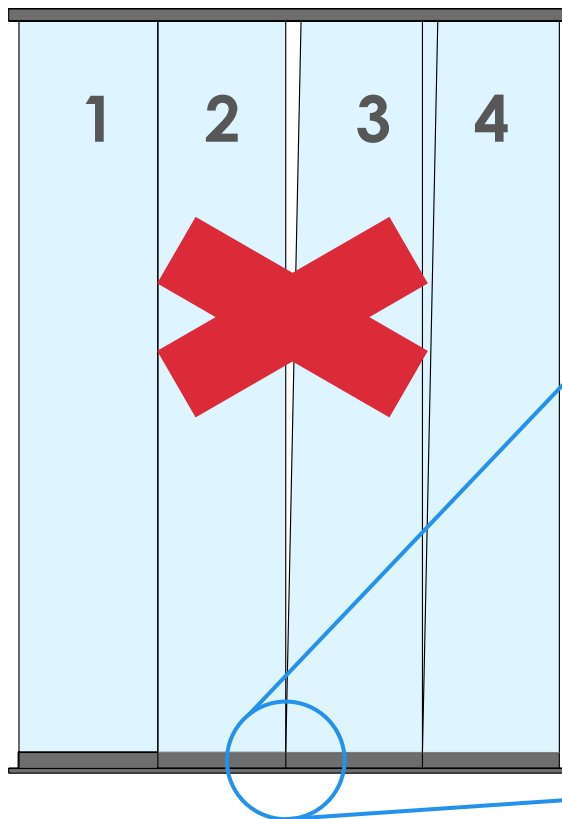

For standard roller sets **CRD006**:

 **4 mm**

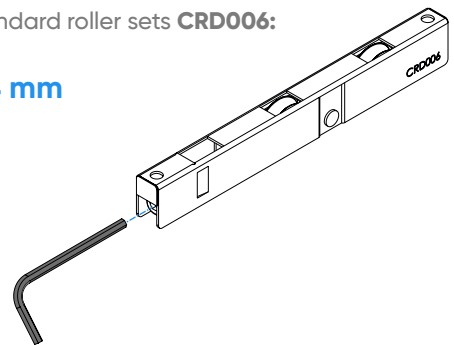

For Premium roller sets **CRD006N**:

 **PH**

 **max. 5.5 mm**

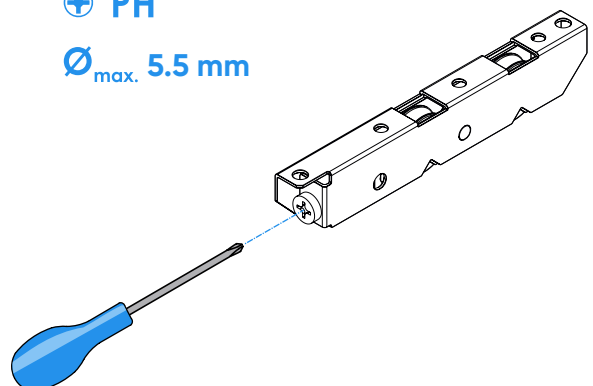



7. STRIP INSTALLATION^{*(2)}

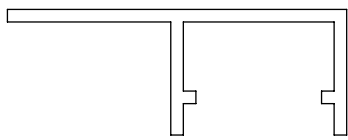

DRAG STRIP

| Glass width | Code |
|-------------|--------|
| 3/8 inches | CRD010 |
| 1/2 inches | CRD012 |

1 Cut the drag strips so that they are lined up with the panel profile and the top track.

2 Once the strips are in position, check that they don't hit the top track and cut if necessary.

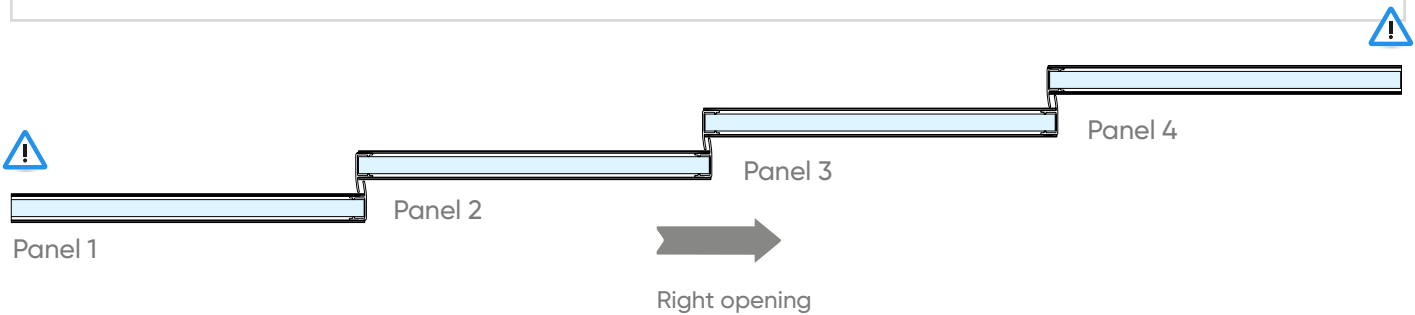
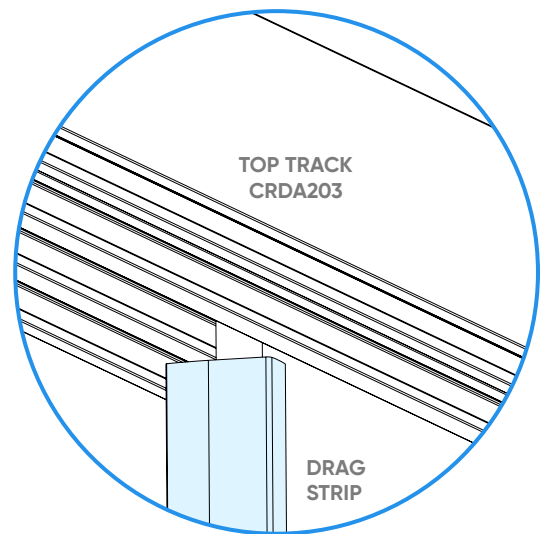
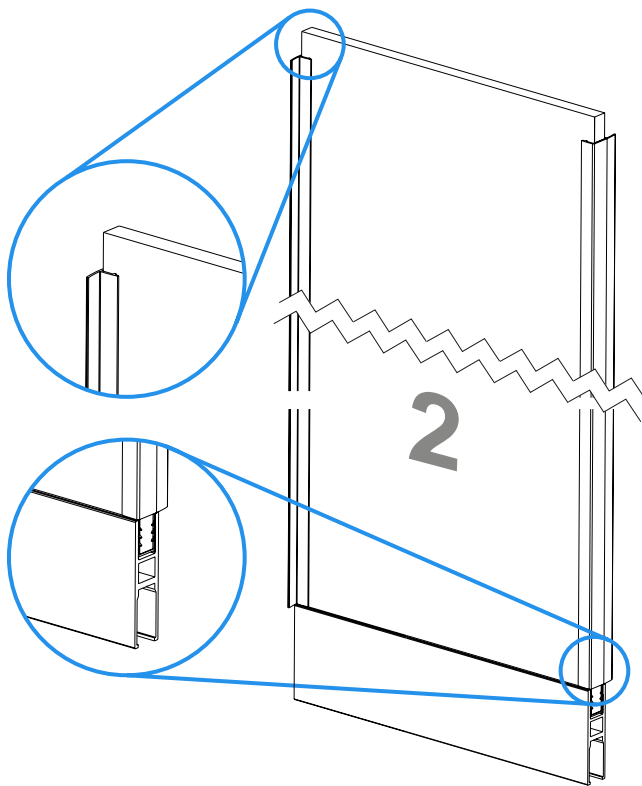

Drag strips are not necessary on the outer edges of the first and last panels.

^{*(2)}. ANNEX 2. Strip installation in systems with central opening or side opening with a lock.

8. STRIKE INSTALLATION IN BOTTOM TRACK



1

Close the system

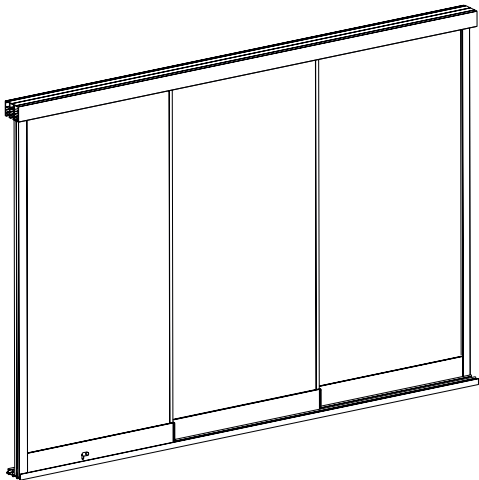

2

Screw the knob into the latch.
(This step is only necessary when the system was manufactured in our workshop).

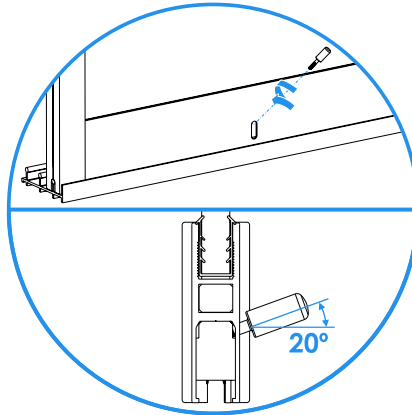

3

Measure from the end of the bottom track to the centre of the latch knob.

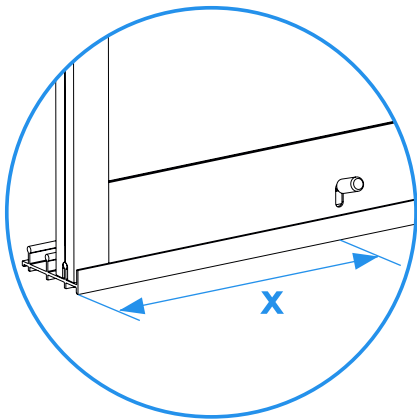

4

Move the panel and centre the strike at the distance measured previously.

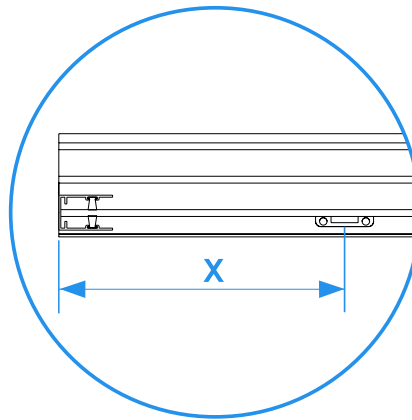

5

Drill using a 1/8 inches drill bit.

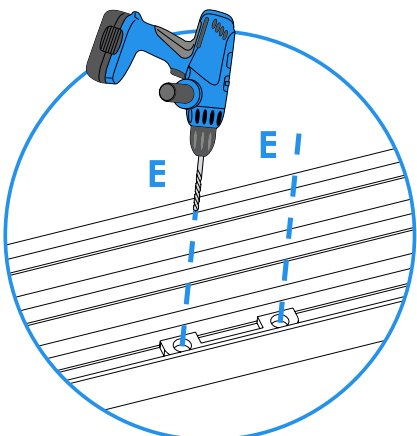

6

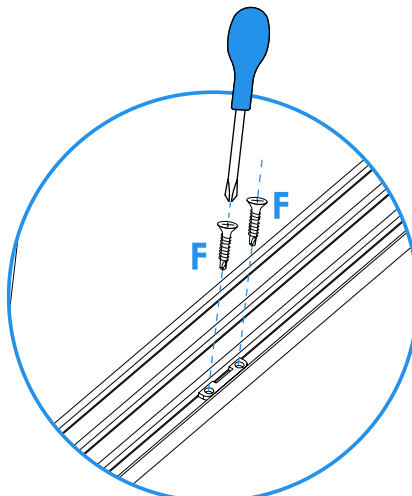

E

Ø 3 mm



F

DIN7504 M3.5X13
TOR002-P



ANNEX 1. TRACK FITTING – Slide mini



THE BOTTOM TRACK MUST BE PLACED ON A FIRM, LEVELED BASE.

1.1 TRACK LEVELLING

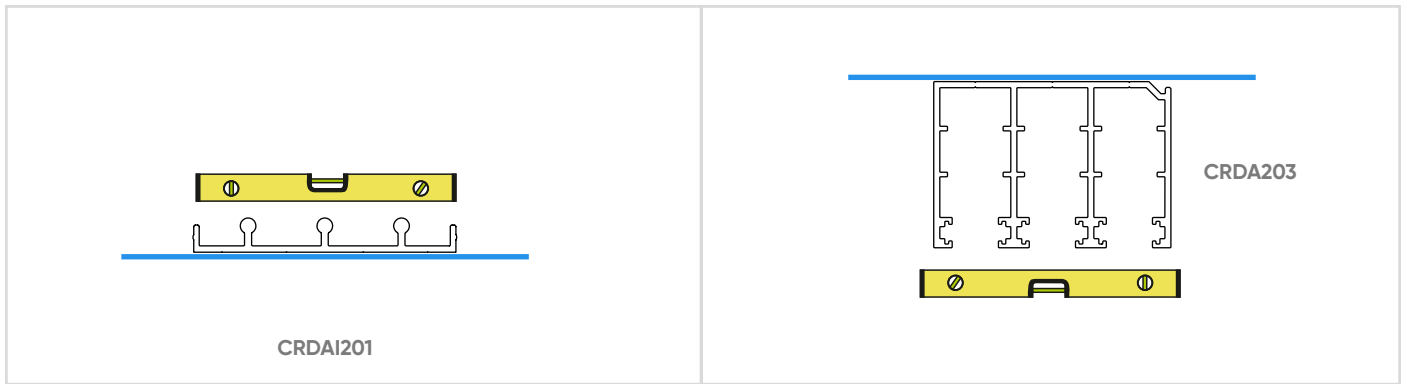

1.2 TRACK ALIGNMENT

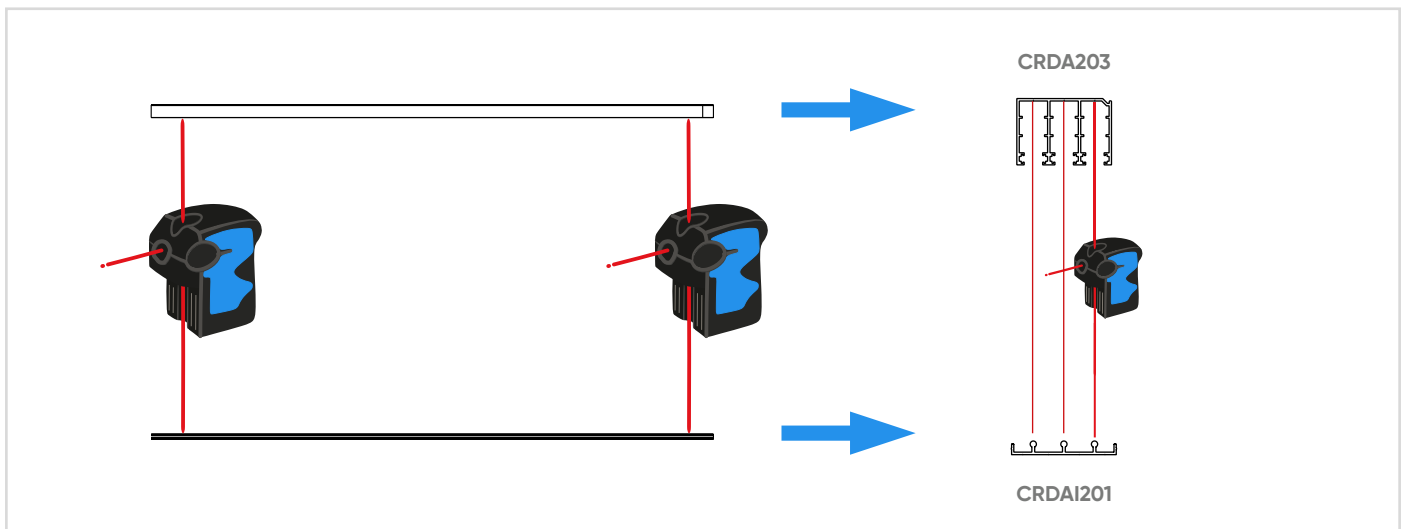

Some Slide mini setups:

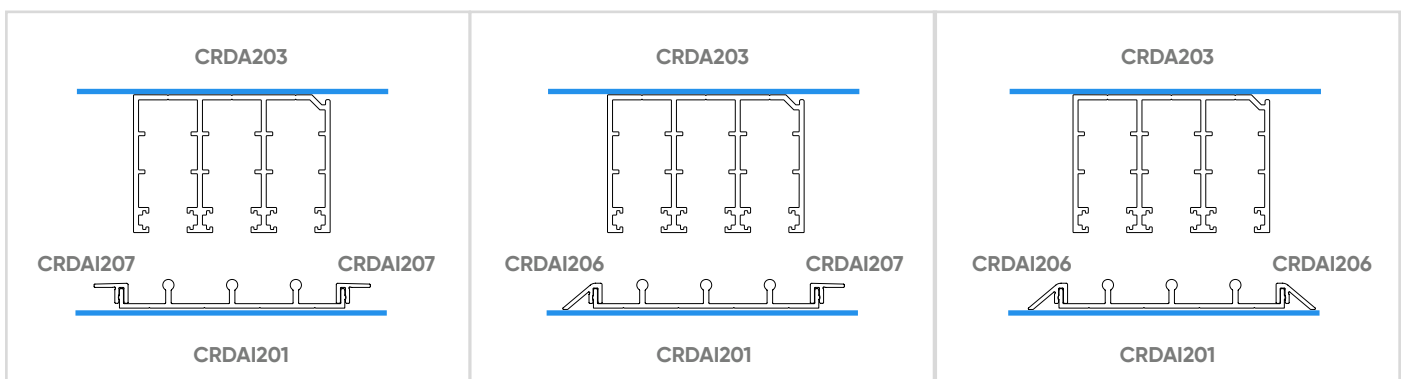

ANNEX 2. STRIP INSTALLATION IN SYSTEMS WITH CENTRAL OPENING OR SIDE OPENING WITH A LOCK

2.1 CENTRAL OPENING

| Glass width | Code |
|-------------|--------|
| 3/8 inches | SIS018 |
| 1/2 inches | SIS100 |

⚠️ Drag strips are not necessary on outer edges of external panels

⚠️ Cut the soft PVC nerves on the inside of the strip.

Hard seal strip

2.2 SIDE OPENING WITH A LOCK

Soft bubble strip

SIS019

Drag strip

Drag strip